



DSZH®

REFRIGERANT GAS LEAK DETECTOR

GLOBAL EXCELLENT SUPPLIER

OF REFRIGERATION TOOLS



HIGH QUALITY TOOLS

Introduction

Congratulations on the purchase of the DS-A-200 Refrigerant Gas Leak Detector, the most technologically advanced of its kind. The DSA-200 low power requirements, small size and high sensitivity combine to create a tool which is easy to handle and ultra effective at locating even the most difficult-to-find leaks. Fully SAE J1627 compliant, the DS-A-200 will detect leaks as small as 0.1 oz/yr (3g/year) in R12, R22, R134a and other halogen refrigerant systems.

DS-A-200 has added useful features to enhance the usability. 1-5 levels range for real-time sensitivity cycle adjustment. 6 pieces of LED displays the leak degree in large range in the form of “gradually lights the light” . and also indicates the sensitivity level . Tactile keypads make the operation more convenient.

Technical data

| | |
|-----------------------|---------------------------------------|
| Dimensions | 17CM X 6CM X 3.8CM |
| Batteries | 2X1.5V'AA' Alkaline Batteries (3 VDC) |
| Battery Life | 40 hours |
| Sensitivity | <3g/year (0.1 oz/yr) |
| Sensor lifetime | approx. 30 hours |
| Operating temperature | 32-122° F (0-50°C) |
| Warm up time | < 2 sec. |
| Response time | instantaneous |
| Reset time | instantaneous |
| Probe length | 12" (30 cm) |

Leak detector frame drawing

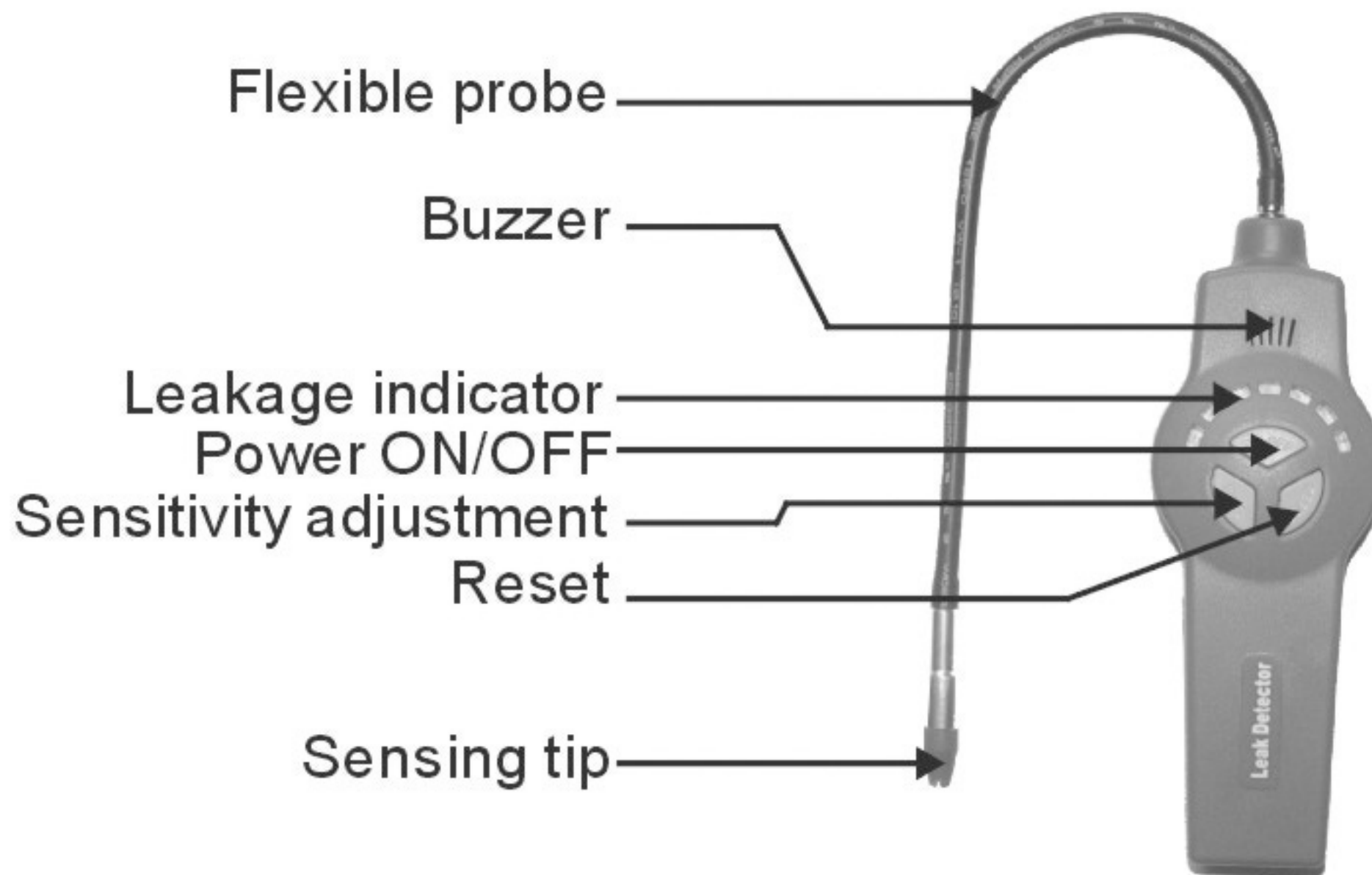

Leak rate indication

HLD-200 with 6 levels of concentration indication to clearly indicate the spillage and strength of leakage. The gradual indicating can be reset, as the increasing level indicates that the source (highest concentration) is being approached.

Battery voltage indication

Please refer to the sketch map to install the battery

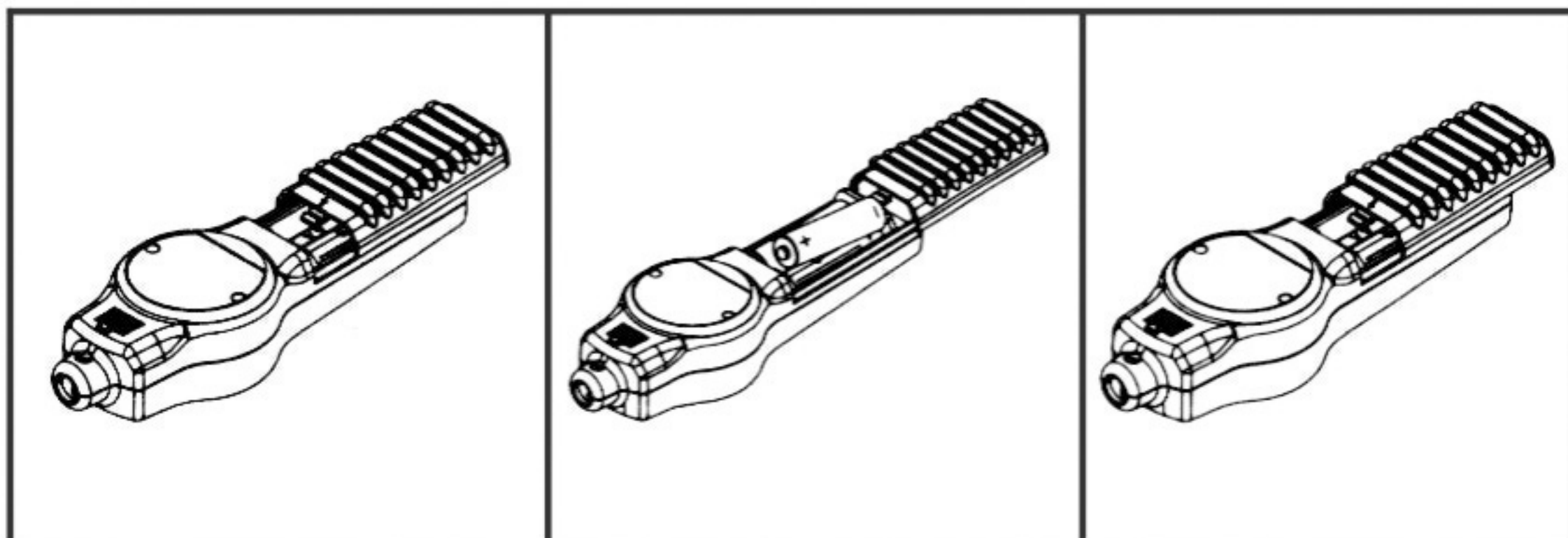

Operation

- Turn on press on/off button, the leak detector enter into self checking status, 7 pieces of LED flash for 5 seconds and all red lights will gradually get dark then enter into normal working status. Press sens enter into the highest sensitivity condition. Meanwhile the leftmost battery indicator light on and show green color (indicates the battery voltage is normal), simultaneously clue on beep every second to indicate that the current concentrations as zero level, and the leak detector is under working condition.
- **Sensitivity adjustment** when the detector is turned on, its sensitivity default is between 4 and 5 level without indicator light .If need to adjust, press sensitivity to set real time sensitivity cycle, and the sensitivity level will be shown on the indicator light. The speed of clue-on beep also changes along with the sensitivity level, on low sensitivity level the tone is slow, and high sensitivity level with rapid tone.
- **Manual reset function** when press reset, all indicator lights lighting for 2 seconds to confirm the reset operation. The detector re-programs the circuit to ignore the level of refrigerant present at the tip. This allows the user for zero adjustment at the leak resource (higher concentration). Similarly, the unit can adjust to get maximum sensitivity level. Resetting the detector in environment without any refrigerant present (fresh air) causes any level over zero to be detected.

Recommended procedure

Note: leak test automotive air-conditioning system should be operated while engine turnoff.

1. The air conditioning or refrigeration system should be filled with sufficient refrigerants to have a standard pressure of at least 340kpa (50psi) while off. At temperatures below 15°C (59° F), leaks may not be detected, since the pressure may not be enough.
2. When the part being tested is contaminated, take care not to contaminate the detector probe tip. If the part is very dirty, or coagulum (water vapor) is present, it should be wiped off with a dry industry-use towel or blown off with industry-use air. No cleansers or solvents should be used, since the detector may be sensitive to their ingredients.
3. Detect the entire refrigerant system, check all conduits, tubes and components whether there is lubricant leakage, mangle and corrosion, and each questionable area should be carefully checked with the detector probe. Also joints, joint of tubes and conduits, refrigerant controls, sealed parts with nuts, and areas around copper pipes and joints of welding lines and patchwork.
4. Always detect the refrigerant system along a continuous path so that no potential leaks will be missed. If a leak is found, always continue to test the remainder of the system. While detecting, the probe should be moved around the

location completely, at a rate no more than 25-50mm/s and distance no more than 5mm from the surface, it will improve the effect of detecting, and a beep indicates that leak is found.

5. At this time, remove the detector and reset the sensitivity to a right level, and check it again to confirm the exact leak position.

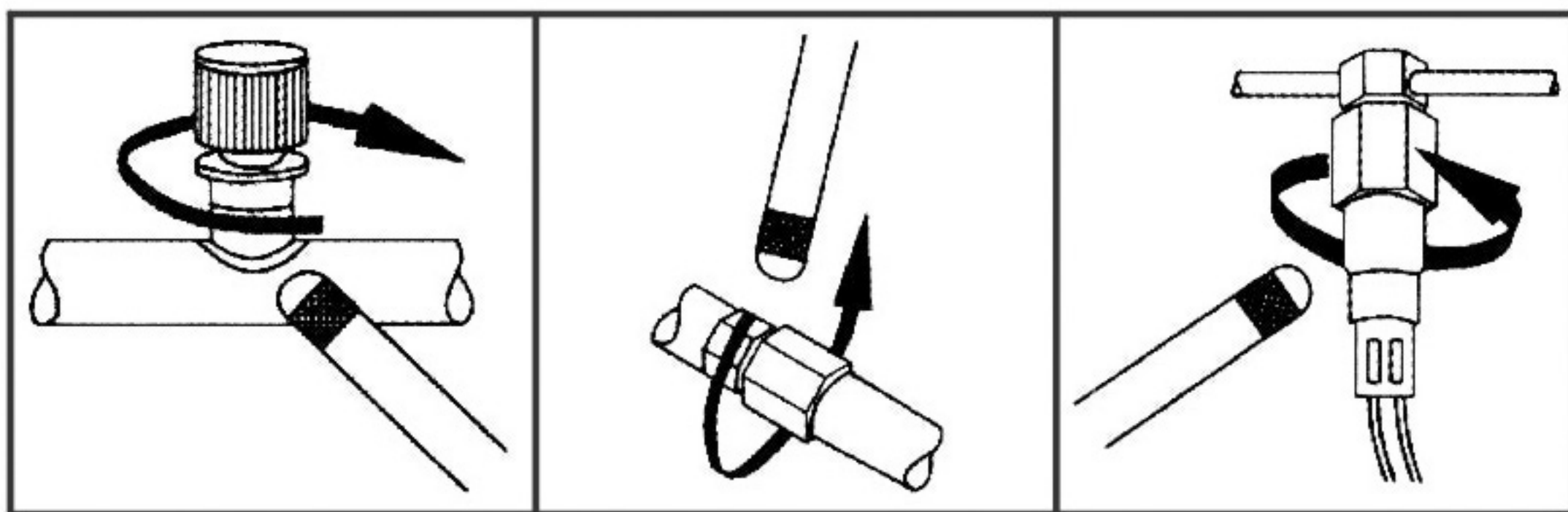

6. An unambiguous leak shall be verified as follow at least once:
 - a. Blow industry-use air into the area of the suspected leak if necessary, and repeat the check of the area. In case of very large leak, blowing off the area with air helps locate the exact position of the leak.
 - b. First move the probe to fresh air to reset, then hold the probe tip as close as possible to the indicated leak source and slowly move around it until the leak is confirmed.

Automotive air-conditioning system only

7. While leak testing of the evaporator's core in the air conditioning module, the air condition fan shall be turned on top grade for at least 15s. Shutting it off, and then

waiting for the refrigerant to accumulate in the case for 10 minutes. After that, insert the detector probe into the fan resistance block or condensate drain hole (if no water is present), or into the closest opening of the evaporator heating/ventilation/air conditioning case, such as the heater duct or a vent pipe. If the detector alarms, a leak has been found.

All systems

8. Following any service to the refrigerant system or any other service which affects the refrigerant system, a leak test should be done to the repaired and service parts.

Operation attention

The following includes universal operation notes and the recommended procedure for leak detection.

1. Adjust the sensitivity up, only when a leak can not be found; adjust the sensitivity down only when resetting the unit does not allow you to zero adjust sensitivity.
2. In areas that are heavily contaminated with gas, reset the detector to ignore the present leakage. Do not move the probe while resetting. The unit can be reset as many times as needed.
3. In windy areas, even a strong leak can be difficult to find. In this condition, it is better to shield the potential leak area.
4. Be aware that the detector may alarm if the probe tip comes into contact with moisture or solvents. Therefore, avoid to contact with them while leak checking.

Applications

The leak detector can be used to:

- Detect leaks in other systems and storage/recovery containers. It will respond to all halogenated refrigerants (including Chlorine and Fluorine). Including but not limited to
 - CFCS e.g. R12, R11, R500, R503 etc.
 - HCFCS e.g. R22, R123, R124, R502 etc.
 - HFCS e.g. R134a, R404a, R125 etc.
- Detect Ethylene Oxide gas leaks in hospital sterilizing equipment (it will detect the homogenate carrier gas).
- Detect SF-6 in high voltage circuit breakers
- Detect most gases including Chlorine, Fluorine and Bromine (halogen gas)
- Detect cleaning agents used in dry cleaning applications such as perchloroethylene
- Detect halogen gases in fire-extinguishing system.

Maintenance

Proper maintenance of your leak detector is very important. Carefully following the instructions as follows will reduce performance problems and increase the life of the unit.

Warning: turn off the unit before replacing the probe tip, or you may get a slight electricity attack.

Keep the probe tip clean:

- Clean shield with industry-use towel or compressed air.
- If the tip itself is dirty, it can be cleaned by immersing in a mild solvent, such as alcohol for a few seconds, and then using compressed air or industry-use towel to clean.

NOTE: never use solvents such as gasoline, turpentine, mineral oil, etc, as the leftover on the probe tip may reduce the sensitivity of detector.

Sensing tip replacement

The tip will eventually abate and need replacing. It is difficult to predict exactly when to replace it, since tip longevity is directly related to the conditions and frequency of use. The tip should be replaced whenever the alarm sounds or become instably in a clean, pure air environment.

To replace the tip

1. Make sure the unit is off.
2. Remove the old tip by unscrewing counter-clockwise.
3. Screw on the spared tip clockwise.

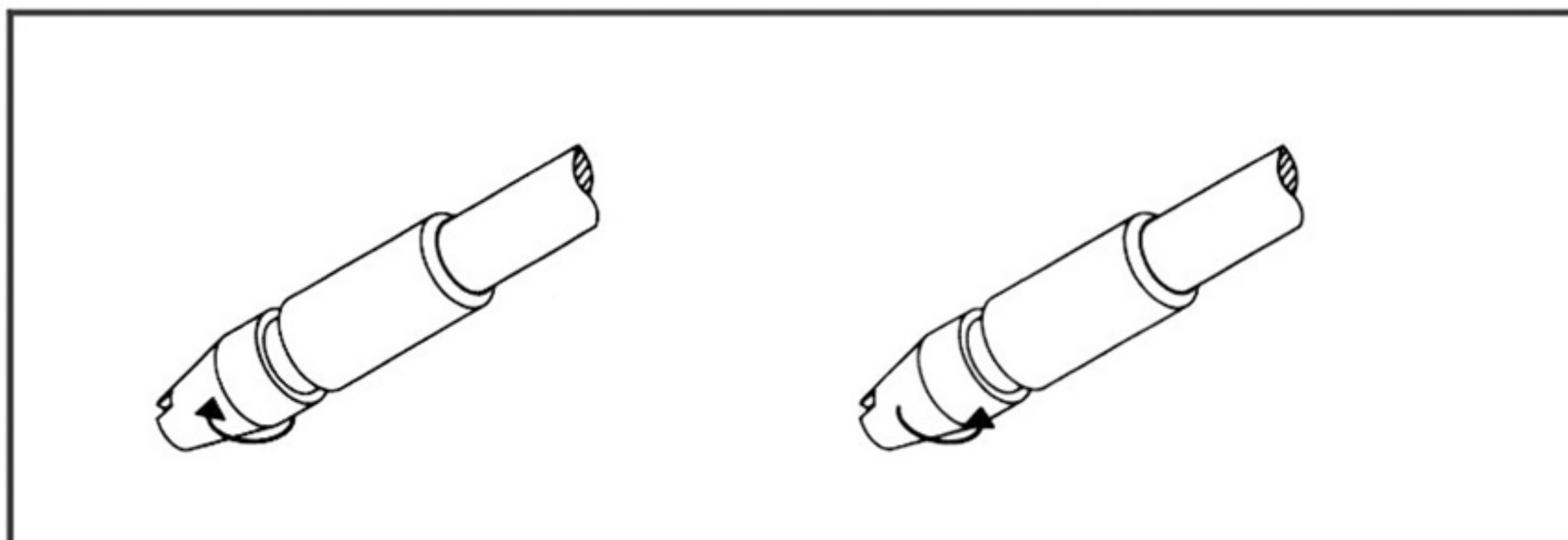

- Save electricity for longer use: Adopt the low-consumption SCM to make the current very small while waiting for working so as to prolong the battery's life.

Warranty

This instrument provide service for life, if the instrument still doesn't work normally after performing the recommended maintenance, a free-charge repair or exchange will be made within one year from the date of purchasing. This warranty is unavailable to those which is man-made damage, wrong use or not make bold to modify. This warranty does not include batteries, sensing tips, tip protectors or any other materials that wear down during normal operation.

Spare parts enclosed:

Plastic case

| | |
|---------------------|-------------------------------------------------|
| Detector | 1 set (including one piece of spared probe tip) |
| High energy battery | 2 cell AA 1.5V |
| Instruction manual. | 1 piece |

DSA-200

DSZH[®]

JINHUA WEIKE INDUSTRIAL & TRADING CO.,LTD.

Add: No. 39 Jinling East Road, Lingxia Industry Zone,
Jindong District, Jinhua, Zhejiang Province, China

Tel: 0579- 82832878 82832879 82832988

Fax: 0579- 82832886

QQ: 120286229

E- Mail: dasheng@cnzongheng.com

Http: //www.cnzongheng.com

PASSED



DATE: _____



MADE IN CHINA

HIGH QUALITY TOOLS